

STRIUM CAPITAN



Post Strium C

Steel post.

Complies with the French decree of 18 September 2012 on technical requirements for accessibility of roads and public spaces.

Available in two diameters: Ø76 and Ø89 mm.
Available in fixed and in removable-fuse version.
Available with flat or domed cap.

Material :
Painted galvanised steel body.

Option :
Brushed stainless steel version.

Finishing :
Polyester powder coating, RAL Ghm.

Weight :
8,5 kg (Ø 76 fixed).
10 kg (Ø89 fixed).

Delivery :
One-piece post (fixed version).

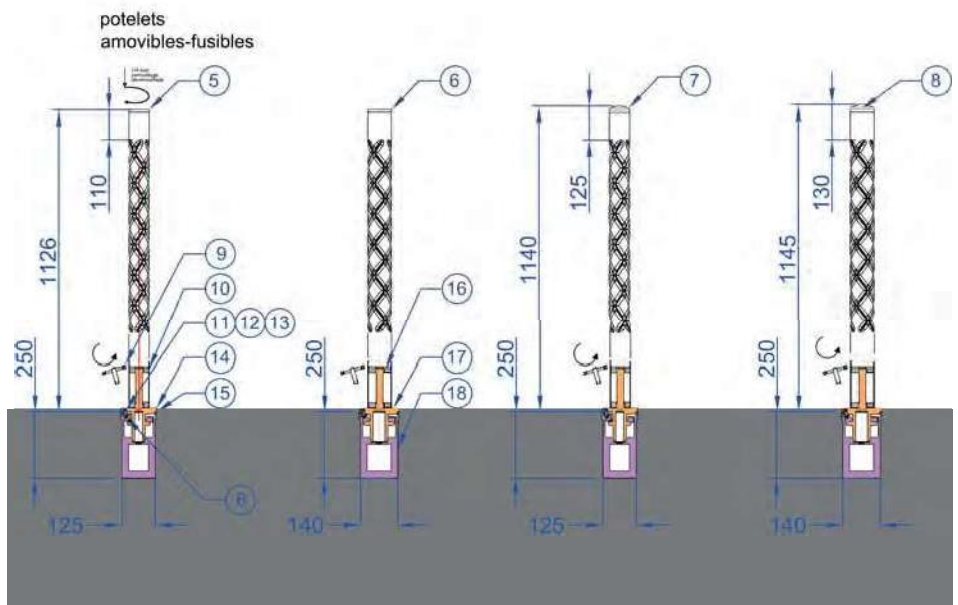
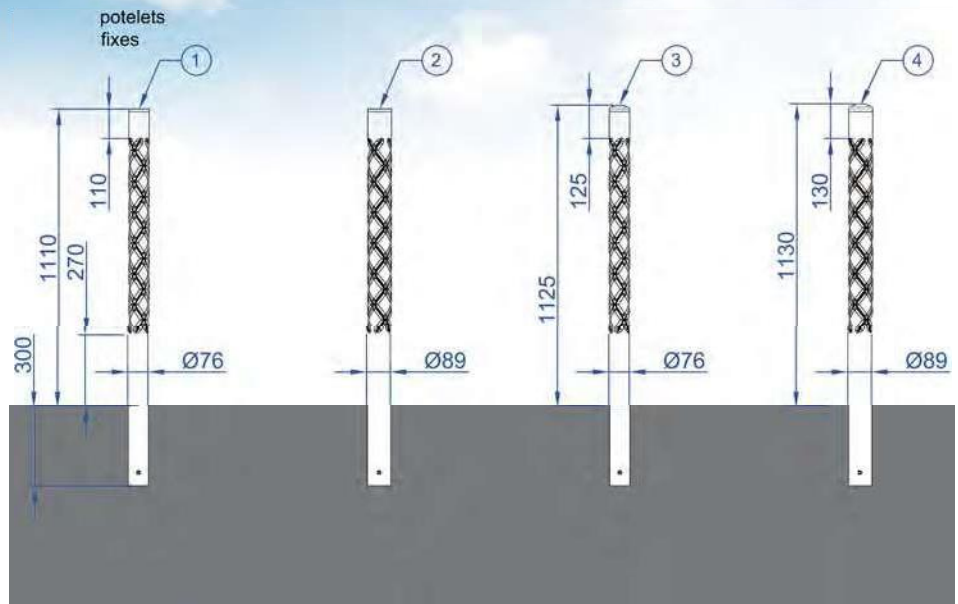

- 18 Cast iron sealing pot EN GJS (6.9kg)
- 17 Cast iron fuse ENGJS (4.2kg)
- 16 2 stainless steel Hc M8x25 screws
- 15 Cast iron can EN GJS (6kg)
- 14 Cast iron fuse ENGJS (3,5kg)
- 13 Stainless steel split pin 2x20
- 12 Stainless steel triangular head screw M10x24
- 11 Washer M10 N
- 10 2 stainless steel Hc screws M8x20
- 9 Standard spanner for 10 mm steel triangle
- 8 Strium post body Ø89 curved removable fuse in galvanised steel (8,9 kg)
- 7 Strium post body Ø76 curved removable fuse in galvanised steel (7,3kg)
- 6 Strium post body Ø89 removable fuse in galvanised steel (9,2 kg)
- 5 Strium post body Ø76 removable fuse in galvanised steel (7,5 kg)
- 4 Strium post body Ø89 fixed curved in galvanised steel (9,9 kg)
- 3 Strium post body Ø76 fixed curved in galvanised steel (8,3 kg)
- 2 Strium post body Ø89 fixed in galvanised steel (10,2 kg)
- 1 Strium post body Ø76 fixed in galvanised steel (8,5 kg)

STRIUM HELIX



Post Strium H

Steel post.

Complies with the French decree of 18 September 2012 on technical requirements for accessibility of roads and public spaces.

Available in two diameters: Ø76 and Ø89 mm.
Available in fixed and in removable-fuse version.
Available with flat or domed cap.

Material :

Painted galvanised steel body.

Option :

Brushed stainless steel version.

Finishing :

Polyester powder coating, RAL Ghm.

Weight :

8,5 kg (Ø76 fixed).

10 kg (Ø89 fixed).

Delivery :

One-piece post (fixed version).

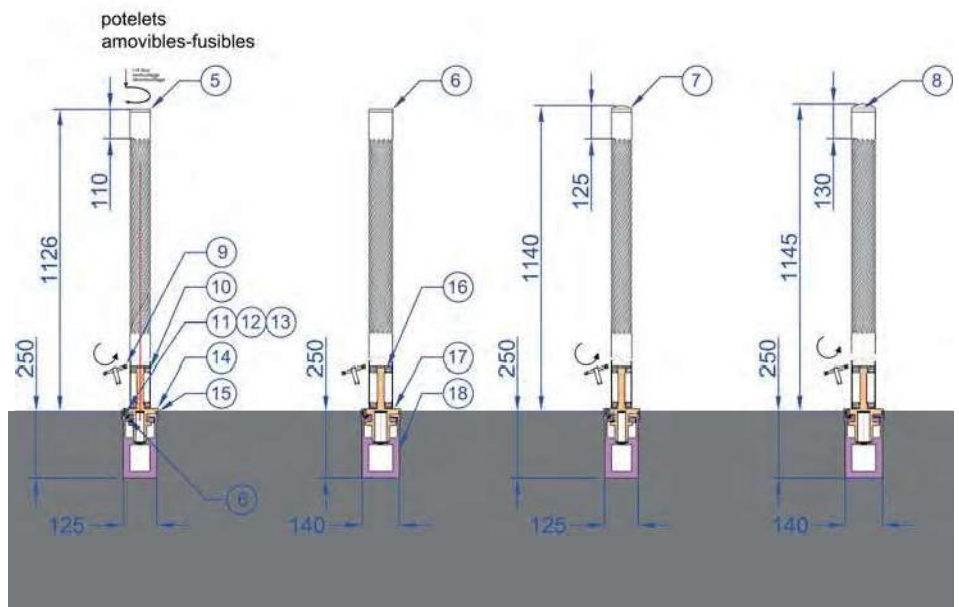
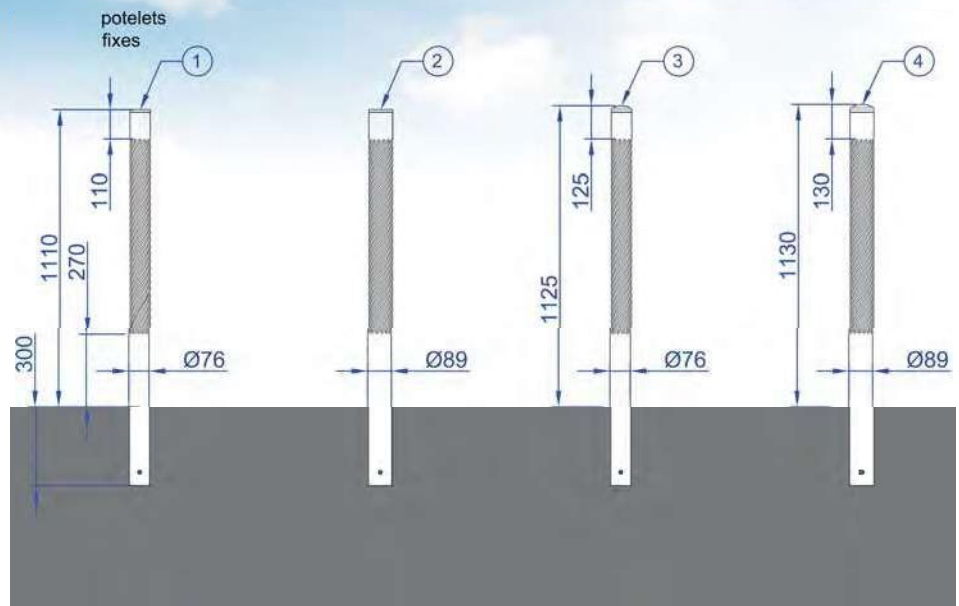

18 Cast iron sealing pot EN GJS (6.9kg)

17 Cast iron fuse ENGJS (4.2kg)

16 2 stainless steel Hc M8x25 screws

15 Cast iron can EN GJS (6kg)

14 Cast iron fuse ENGJS (3,5kg)

13 Stainless steel split pin 2x20

12 Stainless steel triangular head screw M10x24

11 Washer M10 N

10 2 stainless steel Hc screws M8x20

9 Standard spanner for 10 mm steel triangle

8 Strium post body Ø89 curved removable fuse in galvanised steel (8,9 kg)

7 Strium post body Ø76 curved removable fuse in galvanised steel (7,3kg)

6 Strium post body Ø89 removable fuse in galvanised steel (9,2 kg)

5 Strium post body Ø76 removable fuse in galvanised steel (7,5 kg)

4 Strium post body Ø89 fixed curved in galvanised steel (9,9 kg)

3 Strium post body Ø76 fixed curved in galvanised steel (8,3 kg)

2 Strium post body Ø89 fixed in galvanised steel (10,2 kg)

1 Strium post body Ø76 fixed in galvanised steel (8,5 kg)

STRIUM TRAIID



Post Strium T

Steel Post

Complies with the French decree of 18 September 2012 on technical requirements for accessibility of roads and public spaces.

Available in two diameters: Ø76 and Ø89 mm.
Available in fixed and in removable-fuse version.
Available with flat or domed cap.

Material :

Painted galvanised steel body.

Option :

Brushed stainless steel version.

Finishing :

Polyester powder coating, RAL Ghm.

Weight :

8,5 kg (Ø76 fixed).

10 kg (Ø89 fixed).

Delivery :

One-piece post (fixed version).

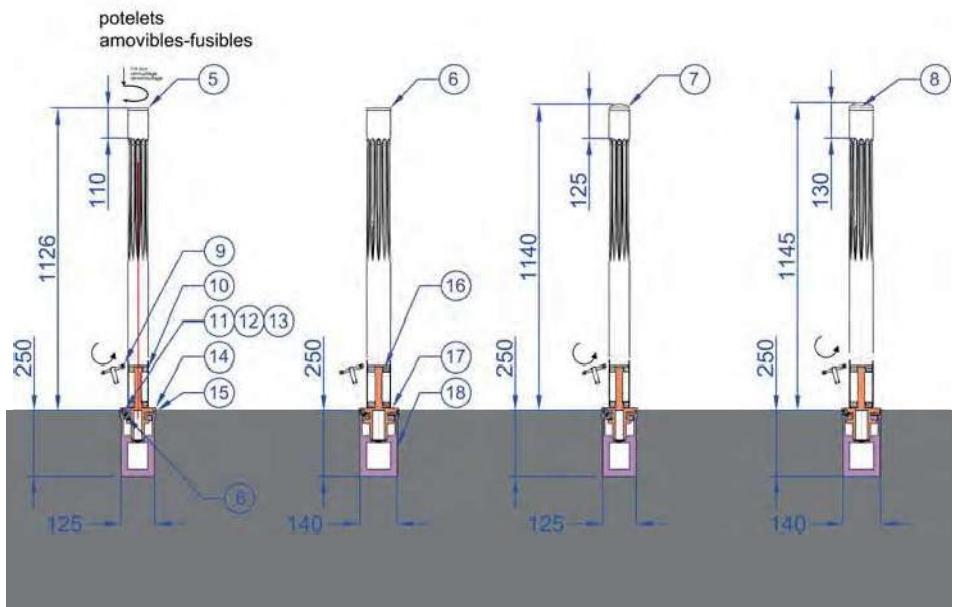
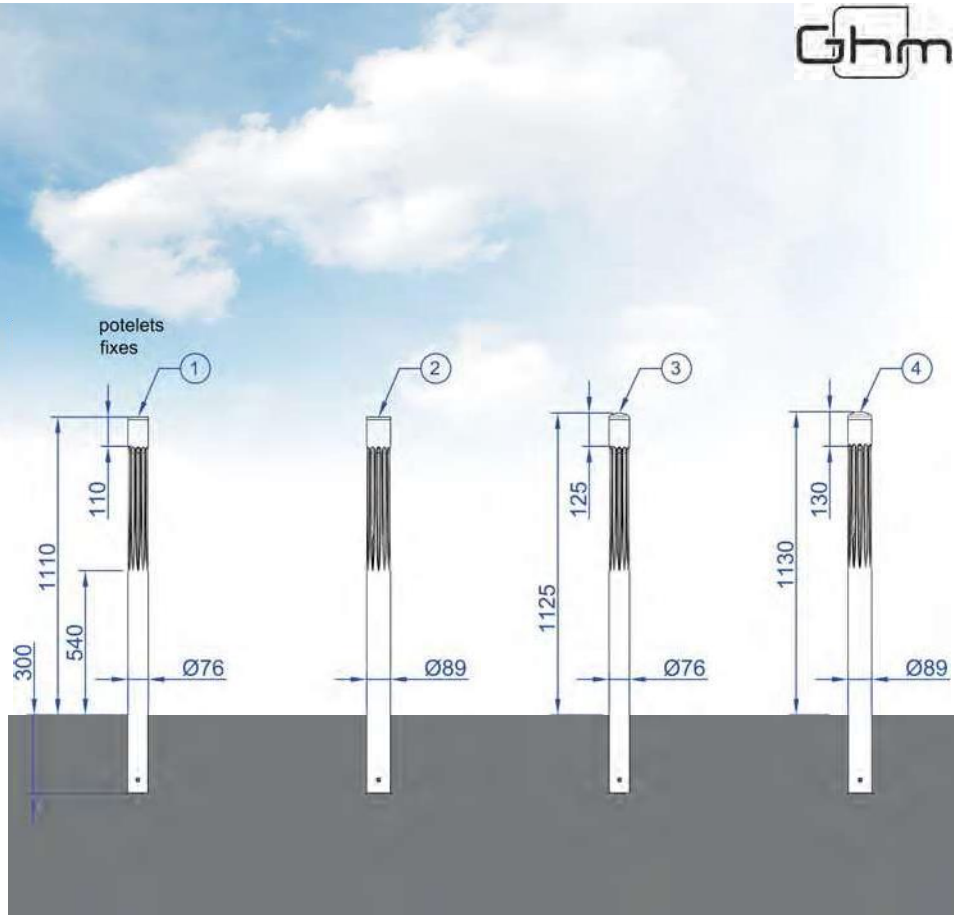

- 18 Cast iron sealing pot EN GJS (6.9kg)
- 17 Cast iron fuse ENGJS (4.2kg)
- 16 2 stainless steel Hc M8x25 screws
- 15 Cast iron sealing pot EN GJS (6kg)
- 14 Cast iron fuse ENGJS (3,5kg)
- 13 Stainless steel split pin 2x20
- 12 Stainless steel triangular head screw M10x24
- 11 Washer M10 N
- 10 2 stainless steel Hc screws M8x20
- 9 Standard spanner for 10 mm steel triangle
- 8 Strium post body Ø89, curved removable fuse in galvanised steel (8,9 kg)
- 7 Strium post body Ø76, curved removable fuse in galvanised steel(7,3kg)
- 6 Strium post body Ø89, removable fuse in galvanised steel (9,2 kg)
- 5 Strium post body Ø76, removable fuse in galvanised steel (7,5 kg)
- 4 Strium post body Ø89, fixed curved in galvanised steel (9,9 kg)
- 3 Strium post body Ø76, fixed curved in galvanised steel (8,3 kg)
- 2 Strium post body Ø89 fixed in galvanised steel (10,2 kg)
- 1 Strium post body Ø76 fixed in galvanised steel (8,5 kg)

